

PYROSPOT Series 80

Portable pyrometer for industrial application

Overview

Portable digital pyrometer with USB interface



- For temperature measurements between 250 °C and 3000 °C
- Spectral and ratio pyrometers
- High precision
- Small measurement spots from 1.9 mm
- Short response times from 2 ms
- Easily focusable precision optics
- True sided through-lens sighting with exact measurement field mark
- Diopter compensation and eye protection filter
- Maximum value storage
- Robust aluminium housing
- Optics for smallest measurement objects
- USB interface

Description and application

The pyrometer series PYROSPOT 80 consists of high precision, robust and powerful devices for application between 250 °C and 3000 °C specifically in heavy industry. The devices PYROSPOT DS 80N and DG 80N are spectral pyrometers, the models PYROSPOT DSR 80N are ratio pyrometers.

There is a 4-digit display and 4 key buttons on the backside of the device. The display shows the current temperature in running measurement mode and the respective parameter when the device is configured via the key buttons.

The optics are focusable continuously, with a wide range, via a screw thread. In this way the measurement distance can be adjusted precisely. By the use of a tempered antireflection coating the lens is extremely robust, easy to clean and in this way suitable for industrial purposes. The very large field of view of the parallax-free through-lens sighting simplifies the targeting of the pyrometer to the measurement object. By an enlarged pupil distance of the ocular the single reflex lens is also operable for spectacle wearers and users with head protection. Pyrometers with a measurement range above 2000 °C are equipped with with an integrated polarization filter to adjust continuously the brightness of the field of view.

The devices have a USB interface on the backside via which the measurement values are transferred to a computer for recording. All parameters can be adjusted on the pyrometer in running mode.



Typical application:

- Iron and steel producing industry
- Metal industry
- Glass and ceramic industry
- Semiconductor industry
- Chemical industry

PYROSPOT Series 80

Portable pyrometer for industrial application

Technical data				
Type	DG 80N	DS 80N	DSR 80N	
Temperature range	250 °C to 2000 °C	500 °C to 2500 °C	650 °C to 1700 °C	850 °C to 3000 °C
Part number	4801071301	4800071301	4802071302	4802071304
Spectral range	1.1 µm to 1.7 µm	0.8 µm to 1.1 µm	0.95 µm/1.05 µm	0.95 µm/1.05 µm
Focus	0.4 m to ∞	0.4 m to ∞	0.4 m to ∞	
Distance ratio	175 : 1	210 : 1	80 : 1	150 : 1
Response time (t98)	≤ 50 ms (T > 250 °C) ≤ 2 ms (T > 750 °C)	≤ 50 ms (T > 550 °C) ≤ 2 ms (T > 750 °C)	10 ms	
Emissivity ratio	10 % to 110 %	10 % to 110 %	1-channel mode: 10 % to 110 % 2-channel mode: 80 % to 120 %	
Measurement uncertainty	0.3 % of meas. value but min. 4 K ¹	0.3 % of meas. value but min. 4 K ¹¹	1 % of meas. value	
Reproducibility	1 K	1 K	2 K	2 K
Temperature coefficient	≤ 0,25 K/K (for T _{ambient} < 500 °C) ² , ≤ 0.05 %/K (for T _{ambient} ≥ 500 °C) ²			
Digital output	periodical measurand output with adjustable cycle time			
Interface	USB			
Resolution display	1 K			
Resolution USB	0.1 K in terminal operation			
Power supply	integrated batteries, power plug			
Battery run-time	approx. 12 hours, in non-stop operation for T _{ambient} = 23 °C			
Humidity limit	95 % r.H. max. (noncondensing)			
Ambient temperature	0 °C to 50 °C			
Storage temperature	-20 °C to 60 °C			
Housing	aluminium			
Safety class	IP40 according to DIN 40050			
Weight	approx. 1.1 kg			
Aiming/Targeting	true sided and parallax-free through-lens sighting with measurement spot mark, diopter compensation and polarization filter			
ATD function	for auto object recognition and measurement value calculation			
Scope of delivery	pyrometer, power plug/recharger, USB cable V/K 11/D (1.8 m), software, protection and transport bag, manual			

¹ For $\epsilon = 1$, $T_{\text{ambient}} = 23 \text{ °C}$. ² of measurement value/K, deviation to $T_{\text{ambient}} = 23 \text{ °C}$.

Dimensional drawing and views

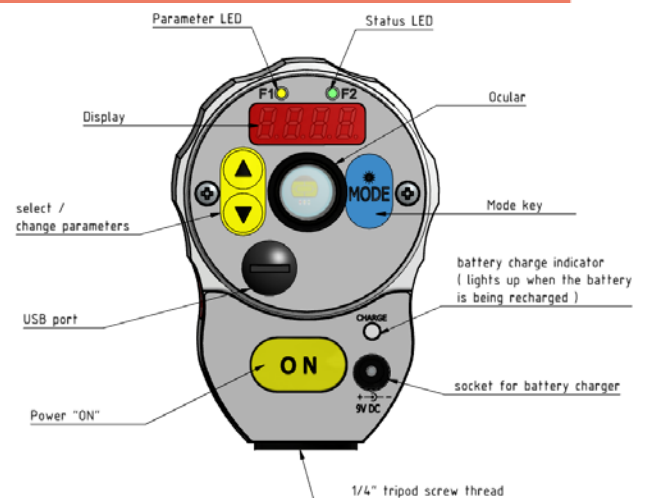
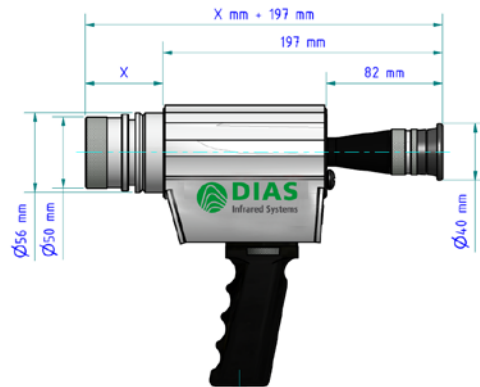
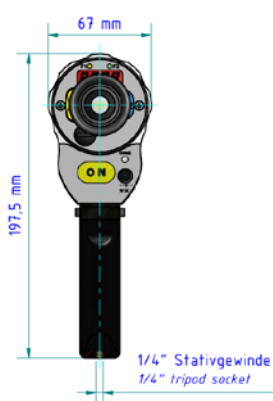

Technische Änderungen vorbehalten. Technical details are subject to change.



We are certified for many years according to ISO 9001

Phone: +49 351 896 74-0
 Fax: +49 351 896 74-99
 Email: info@dias-infrared.de
 Web: www.dias-infrared.com

DIAS Infrared GmbH
 Pforzheimer Straße 21
 01189 Dresden
 Germany