

ControlMaster CMF310

Universal process controller, fieldmount

Making process control easy

Measurement made easy



Cost saving field-mount design

- Wall-, pipe- or panel-mountable
- No need for an instrument panel
- IP66 and NEMA4X environmental protection

Comprehensive display of process status

- Crystal-clear, full-color TFT display
- User-customizable
- Historical trending

Exceptionally easy-to-use

- Intuitive user interface and clear text prompts ensure installation, commissioning and operation are quick and simple

Scalable to match application requirements

- Comprehensive hardware- and software-options

Powerful control functionality

- Cascade, feed-forward, ratio, predictive- and adaptive-control strategies
- Dual-loop capability

Problem-solving capability

- Flexible functionality including math, logic and totalization providing power to solve complex application requirements

Flexible connectivity

- Ethernet and MODBUS® communications

Profile control

- Comprehensive setpoint profiling capabilities

ControlMaster CMF310

Universal process controller, fieldmount

Overview

The ControlMaster CMF310 is a highly versatile, field-mountable, universal PID process controller. With a unique field-mountable design that enables wall-, or pipe-mounting without the need for an additional enclosure. Detailed process information is presented clearly on the CMF310's full-color TFT display and an intuitive operator interface simplifies configuration and operation.

Highly scalable in both hardware and software functionality, a CMF310 can be specified easily to meet the needs of virtually any process control application – simple or advanced. Powerful control functions such as adaptive control, math, logic and totalization provide problem-solving flexibility and make the CMF310 suitable for a wide range of process applications.

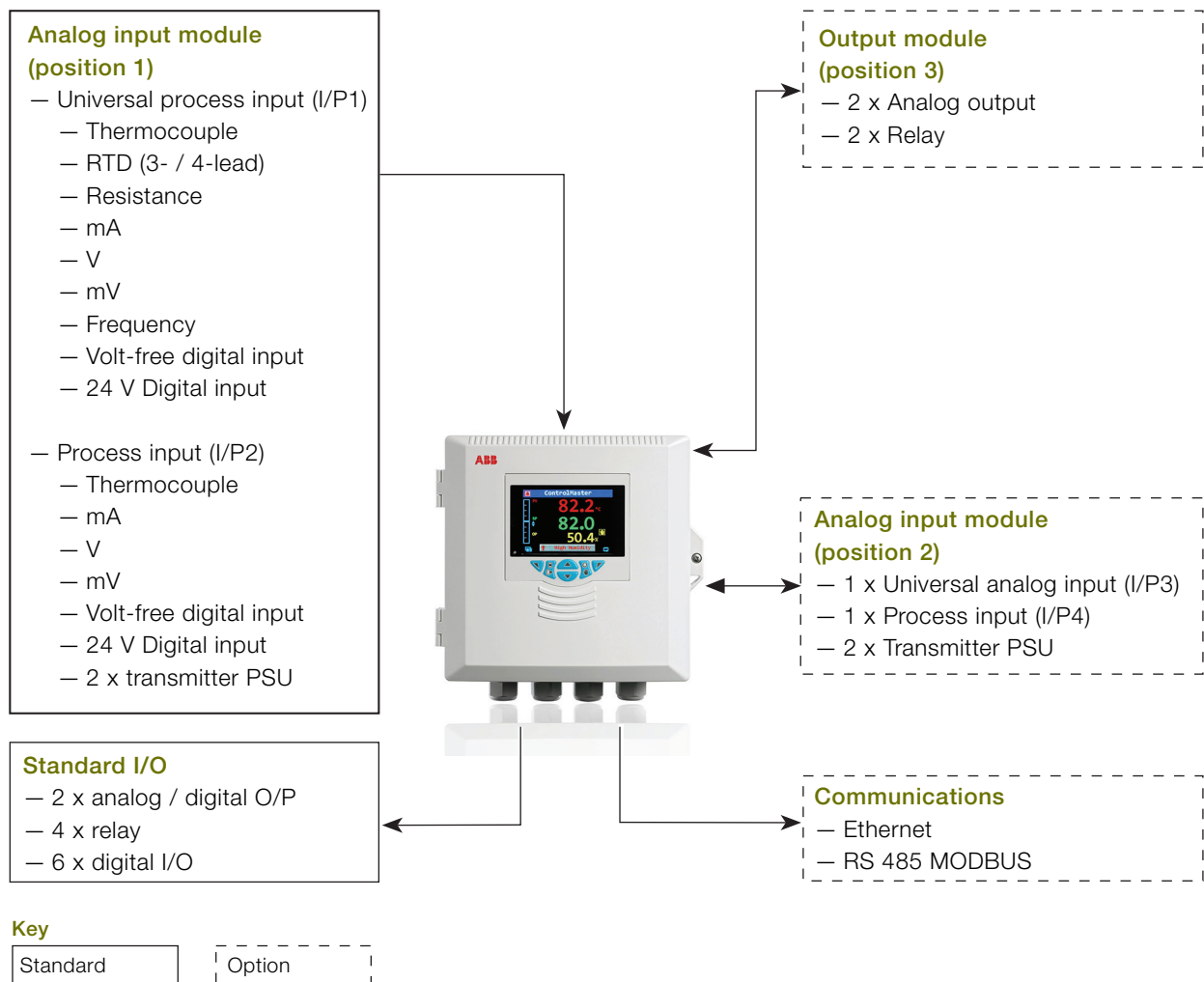

Fully configurable via the easy-to-navigate front panel menus or PC configuration software, the CMF310 can be commissioned rapidly and then tuned via the advanced autotune capability.

MODBUS and Ethernet communication options ensure easy integration into a control system.

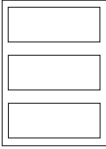
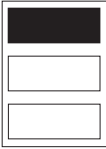
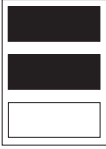

Highly scalable

The CMF310 is highly scalable in terms of both hardware and software, to fulfill the demands of the simplest to the most complex process. The basic CMF310 meets the needs of a simple control loop. Templates and control functionality can be increased by adding function keys to the basic model. Each function key added provides additional templates and functionality as shown in Fig. 1, while retaining previous templates and functionality. For I/O builds, see Ordering information on page 22.

Level	Function keys	Template	Functionality
Base	0 	Single loop Single loop with remote setpoint	Process alarms Basic setpoint switching Basic control <ul style="list-style-type: none"> – Analog PID – On / Off or time proportioning – Auto tune – Split output control
Standard	1 	Auto / Manual station low signal selection Auto / Manual station digital signal selection Analog backup station low signal selection Analog backup station digital signal selection Single indicator / manual loader Dual indicator / manual loader	Standard setpoint switching Standard control <ul style="list-style-type: none"> – Gain scheduling – Motorized valve control Output tracking Logic Math Custom linearizers Delay timers Real time alarms Standard profile Bank control Template customization
Extended	2 	Single loop with feedforward Single loop with feedforward and remote setpoint ‡ Cascade Cascade with remote setpoint ‡ Cascade with feedforward ‡ Ratio controller (internal ratio) Ratio controller (external ratio) ‡ Ratio station (internal ratio) Ratio station (external ratio) ‡	Totalization Advanced profile Advanced control <ul style="list-style-type: none"> – Feed forward – Predictive control – Adaptive control Historical trending Display customization
Dual Loop	3 	Dual loop – local / local Dual loop – remote / local ‡ Dual loop – remote / remote ‡	

Recommended I/O Build: Unless analog values are being digitally communicated to the CMF310, an analog input module is required in position 1.
For templates marked ‡, an additional analog input module is required

Fig. 1: Overview of template options

ControlMaster CMF310

Universal process controller, fieldmount

Powerful operator display

The CMF310 features a full-color 9 cm (3.5 in.) display for displaying detailed process information to the user. Process details such as alarm messages and diagnostic information are displayed clearly in full text without the need for difficult-to-read scrolling displays.

Example of an operator page

Automatic selection of standard display templates immediately makes best use of the CMF310's display. Extensive customization features then enable the displayed information to be tailored to suit the process requirements.

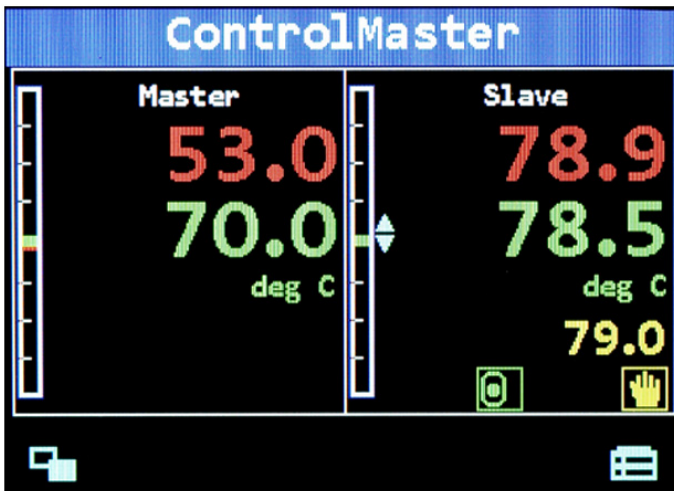

Fig. 2: Cascade template display

Diagnostics and alarm status display

The diagnostics and alarm status display provides detailed information on any active alarm or diagnostic condition. The operator can see, at-a-glance, the status of any alarm condition present within the process. In addition, diagnostic messages are presented clearly to the operator, enabling rapid notification and simple diagnosis of any critical instrument status condition.

Historical information of diagnostic messages can also be viewed in the controller's diagnostic log.

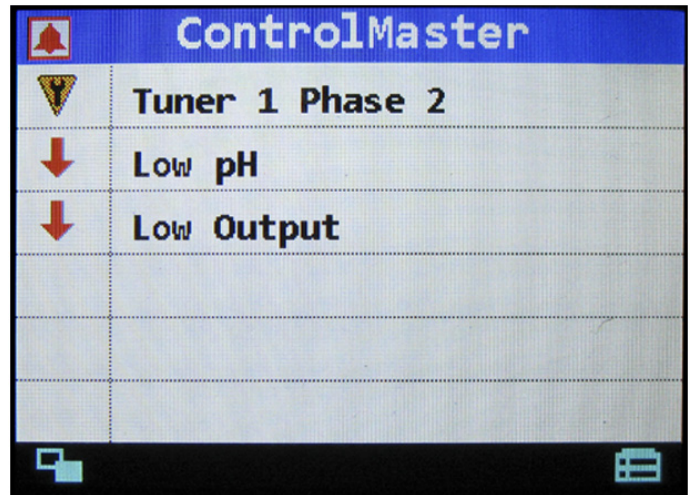

Fig. 3: Alarm status display

Trend display

Any 2 analog values within the CMF310 can be plotted on the trend display to provide a short-term process history. This feature enables control efficiency to be monitored against setpoint and assists in tuning during commissioning.

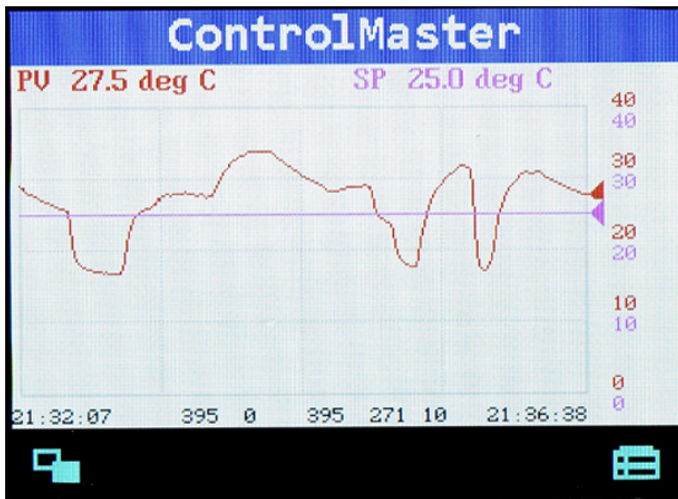

Fig. 4: Trend display

Exceptionally easy to use

The CMF310's full text display and simple-to-navigate, pop-up menu makes operation exceptionally easy.

A programmable soft key enables commonly used functions, such as alarm acknowledgement and display selection, to be accessed easily by the operator.

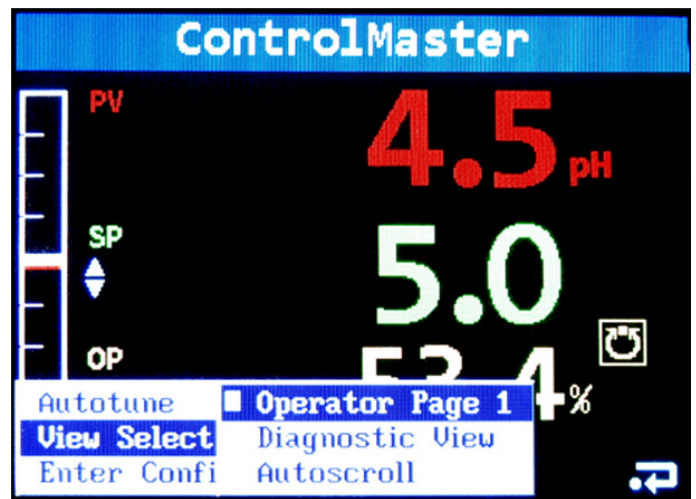

Fig. 5: Pop-up menu

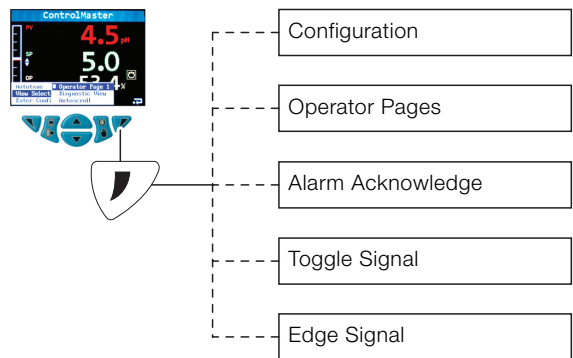

Fig. 6: Programmable soft key

ControlMaster CMF310

Universal process controller, fieldmount

Advanced control functionality

The CMF310 features many advanced control functions providing the power to bring even the most complex process under control.

Autotune

Once initial configuration is complete, a powerful autotune facility enables automatic calculation of the PID values required, enabling rapid commissioning of the CMF310.

Gain scheduling

The CMF310's gain scheduling functionality is used for efficient control of non-linear processes. Up to 3 different sets of PID parameters are selected automatically from a reference signal ensuring optimum control response, regardless of the process status.

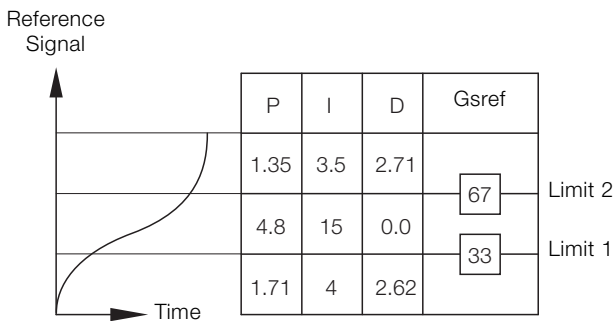

Fig. 7: Gain scheduling example

Predictive control (dead-time compensation)

Control of processes with long dead-times, such as pH dosing in a pipeline, is addressed easily using pPI control. Configured via only 3 parameters (gain, integral time and dead-time), pPI control can also be combined with gain scheduling for optimum control efficiency.

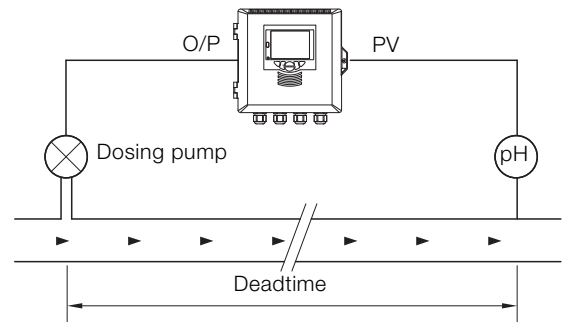

Fig. 8: Predictive control example

Adaptive control

Adaptive control enables the CMF310 to adjust its control response automatically to suit changing process dynamics. This makes the CMF310 particularly useful for processes with varying or uncontrolled types of load, by providing continuous tuning to maximize control efficiency. Fig. 9 shows a product used in a manufacturing process that is stored in an outside tank. The use of adaptive control within the manufacturing process compensates automatically for the change in product temperature caused by seasonal variation.

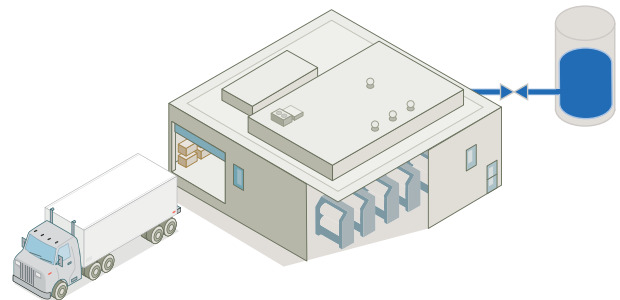

Fig. 9: Adaptive control example

Split output control

The CMF310 can also be configured to perform split output control, for example, when both heating and cooling of a single process is required.

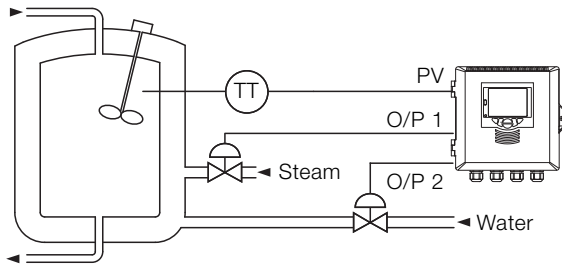

Fig. 10: Split output control example

Remote auto / manual switching

In addition to switching via the front panel, the CMF310 can be switched between automatic and manual control mode using an external signal. When switched to manual mode via a digital signal, the value of the control output can be preset, for example, to fully open a control valve automatically during a cleaning cycle.

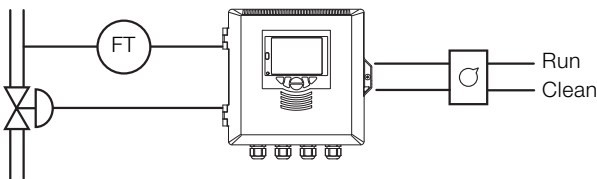

Fig. 11: Remote auto / manual switching

External setpoint selection

The CMF310's control setpoint can be selected via external digital signals, for example, simplifying operation by selecting different setpoints using external push buttons.

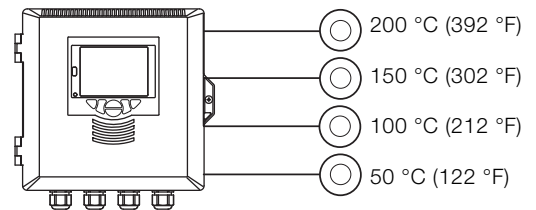

Fig. 12: External setpoint selection

Bank control

Bank control enables improved control of multi-element output devices such as banks of heaters, pumps and fans. Aimed at minimizing wear caused by over-use of one specific 'duty' device, bank control enables wear to be levelled by sharing duty and assist handling between every device in the bank. Bank control gives users the choice of either 'Rotate' or 'First In, First Out (FIFO)' wear-levelling schedules. If required, bank control can be combined with PID control, assigning the PID output signal to the bank control function.

Bank control can also be utilized when split output control is configured. For example, when two variable speed pumps are being controlled in a duty assist configuration. Each time both pumps are stopped the duty and assist outputs are alternated.

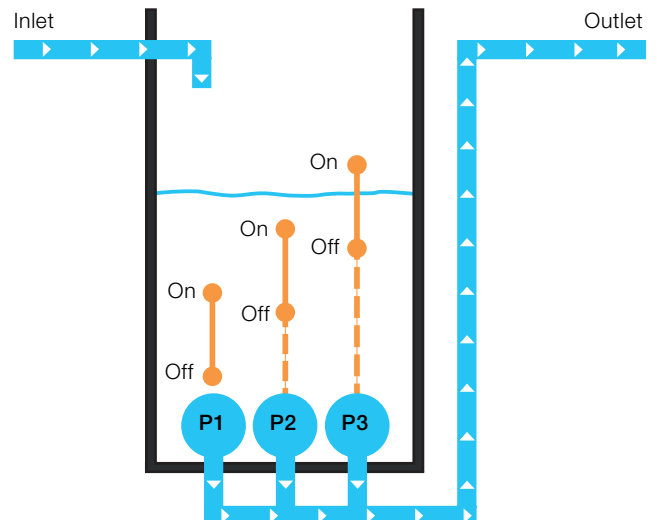

Fig. 13: Independent on and off trip points

ControlMaster CMF310

Universal process controller, fieldmount

Problem solving flexibility

Extensive functionality is available to provide flexible problem-solving capability; making the CMF310 much more than just a process controller.

Process alarms

8 independent process alarms can monitor any analog signal within the CMF310, enabling extensive process monitoring capability. Alarms can be used to drive physical outputs or soft-wired to other functions within the controller.

Real-time alarms

The 'alarm clock' functionality provided by the CMF310's real-time alarms enables time-of-day decisions to be introduced into the controller's actions or specific functions to be triggered routinely at specified times.

Delay timers

Event sequencing is enabled through the use of the CMF310's delay timers. A predetermined delay and output duration can be programmed into each delay timer and timers can be linked together.

Custom linearizers

The CMF310 has 2 independent 20-point custom linearizers that can be applied to any analog signal within the controller. These linearizers can be used in applications such as level-to-volume conversion of a non-linear tank level or to accommodate special input signals or output devices.

Math

8 math blocks provide arithmetic, averaging, min. / max. hold, square root and signal switching functionality. Simple equations can be performed in a single math block or multiple math blocks can be nested together to construct complex equations.

Signal switching 'multiplexer' math blocks switch between 2 analog signals based on a trigger signal. For example, a backup sensor could be selected automatically on failure of a primary sensor.

Logic

8 comprehensive logic equations provide powerful interlock functionality. Inputs and outputs of the logic equations can be soft-wired to any digital signal within the controller to maximize flexibility.

Totalizer

2 totalizers are available on the CMF310. The totalizers can be configured to perform multiple functions:

- integration against an analog signal to totalize flow
- counting digital pulses
- totalization of flow based on a frequency signal from an electromagnetic flow meter

Communications

Extensive communication options enable the CMF310 to be integrated into larger control systems easily or connected to other process instrumentation.

Ethernet

Optional Ethernet communications enable the CMF310 to be integrated in to an Ethernet network quickly. The following functionality is provided:

– Email

Notification of a critical process event or status can be made by email. Multiple events can trigger an email that can be sent to multiple recipients

– Webserver

The CMF's integrated webserver enables the current status of the process and controller to be viewed remotely using a standard web browser

– MODBUS TCP

Process values and status can be communicated to, and from, the CMF310 in real-time using MODBUS TCP, enabling it to be integrated easily into larger control systems or connected to a data recorder

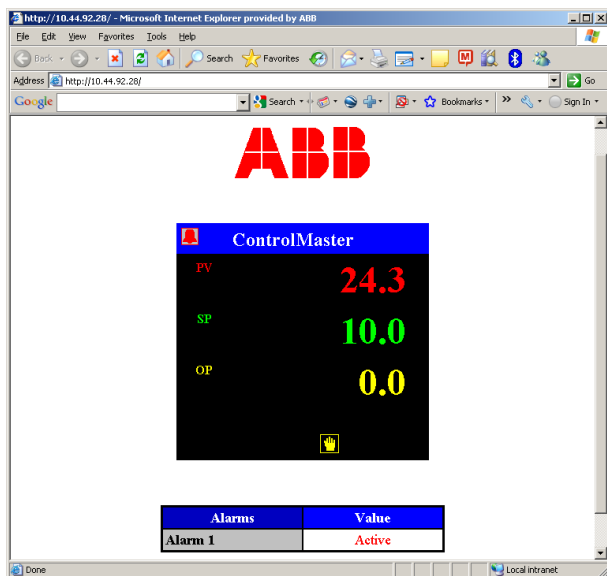

Fig. 14: Integrated web server

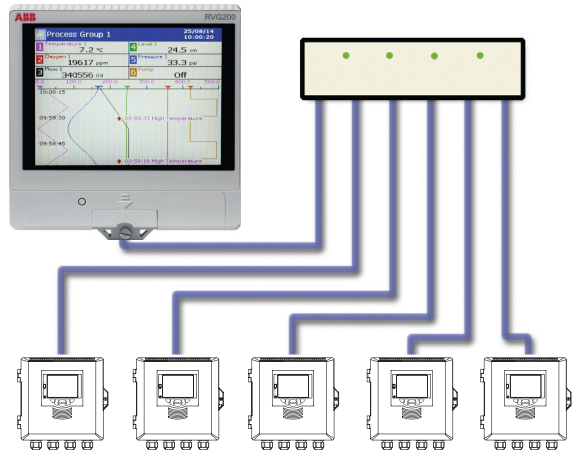

Fig. 15: ControlMaster CMF310s connected to a ScreenMaster

RS 485 MODBUS

Using RS 485 MODBUS, values and status can be communicated to, and from, the controller in real-time via an RS 485 connection.

PC Configuration Backup

Once configured using the intuitive on-screen configuration menus, a CMF310s configuration can then be backed up to a PC using an infrared connection. In addition to being saved for future use, configurations backed up to a PC can be downloaded to other CMF310 controllers.

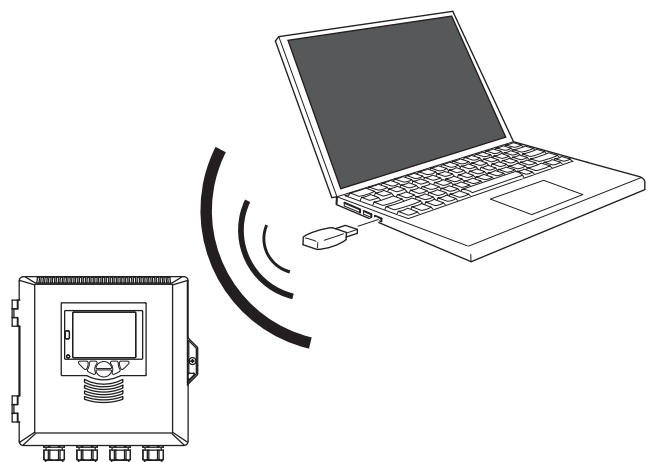

Fig. 16: Transferring a configuration file via the infrared port

ControlMaster CMF310

Universal process controller, fieldmount

Setpoint profile

Setpoint profile capabilities make the CMF310 ideally suited to thermal processing applications where a specific temperature profile needs to be followed. Profiles are quickly created by programming a series of segments (for example, ramp, hold, wait or step). Process operators can then easily activate and monitor the required program via dedicated profile operator displays and menus.

Profile control is available in two versions:

— **Standard Profile:**

ideal for simple applications standard functionality provides a single program of up to 10 segments.

— **Advanced Profile:**

capable of accommodating 30 programs, advanced functionality provides 140 programmable segments and powerful features such as sequencing and timed-, or segment-events.

Fast run mode

When activated fast run mode runs a profile at 8 times normal speed allowing complex or long duration programs to be tested prior to use.

Guaranteed Ramp / Soak

For processes where strict tolerances must be adhered to during a profile cycle, guaranteed ramp/soak can be applied to appropriate segments. A configurable hysteresis can be applied to a segment; if the process variable exceeds these limits the program is placed on hold until the process recovers. Once back within limits the profile can be configured to continue, or repeat, the current segment. Hysteresis limits can be above, below or above and below the setpoint value.

Sequencing and interlocks

Advanced profile functionality provides features that enable sequencing and control of peripheral devices that must be activated at specific points during a profile. For example, valves and cooling fans can be driven by segment events that are freely configurable throughout a profile program. In addition, the setpoint for slave controllers can be generated by an analog user value which is programmable for each segment of a profile program.

When interlocks are required, wait segments can be placed in a program. On arriving at a wait segment the profile waits until a required condition is met (for example, digital input received) before continuing with the program.

Dedicated profile displays

To make day-to-day operation as easy as possible, profile control has dedicated display templates. A concise display detailing the program name, status and time remaining is shown to the operator. A more detailed program and segment status information is available on sub-pages.

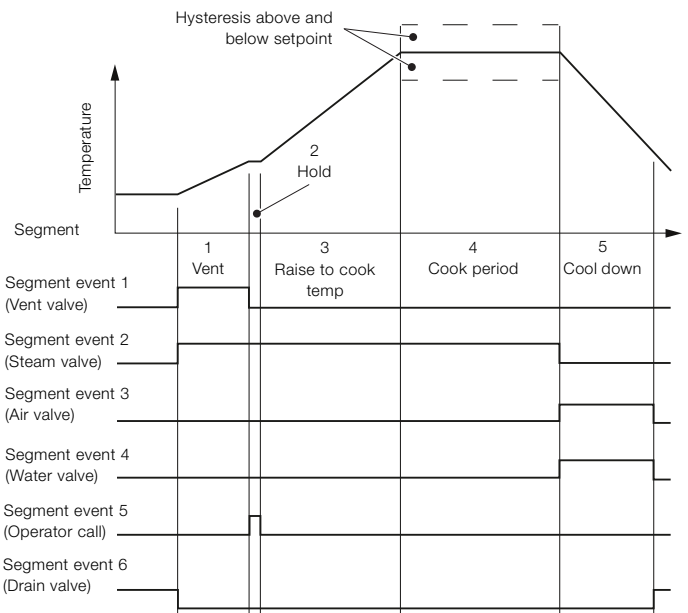

Fig. 17: Profile control

Application templates

To minimize commissioning time, the CMF310 features up to 20 preconfigured control strategy templates. By selecting the required control strategy, the template configures the CMF310's function blocks and display automatically. Customization of the preconfigured templates is also possible, providing the flexibility to create customized solutions.

Single loop

This template provides standard, single-loop process control and is available with or without a remote setpoint. In this example, the temperature of a product heated by a heat exchanger is regulated via the control of the steam feed to the heat exchanger.

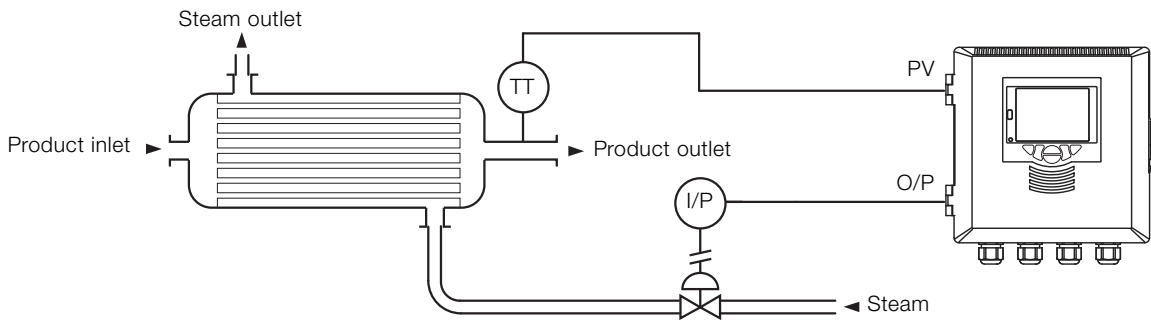

Single loop with feed-forward

This template adds feed-forward functionality to the single-loop template and is available with or without a remote setpoint. Feed-forward control enables the CMF310 to anticipate, and respond to, process occurrences not yet detected by the process variable signal.

In this example, the CMF310 is regulating the speed of a dosing pump used to neutralize the pH of waste discharge. The flow rate of the waste discharge is monitored and fed forward to the CMF310 so that, as the flow rate increases, the speed of the dosing pump increases automatically to neutralize the extra volume of waste discharge.

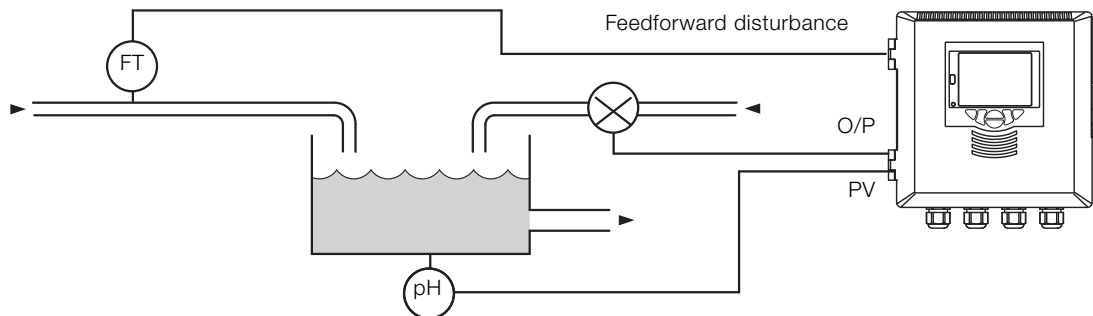

ControlMaster CMF310

Universal process controller, fieldmount

Cascade

The cascade template connects two PID loops together to enhance the control of a master variable (master loop) by manipulation of a slave loop.

In this example, the temperature of a furnace is regulated (master loop) by monitoring and controlling the gas flow rate to the burner (slave loop). By performing slave loop control on the gas flow rate, variations in gas supply can be accounted for and better temperature control performance achieved. This template is available with or without a remote setpoint.

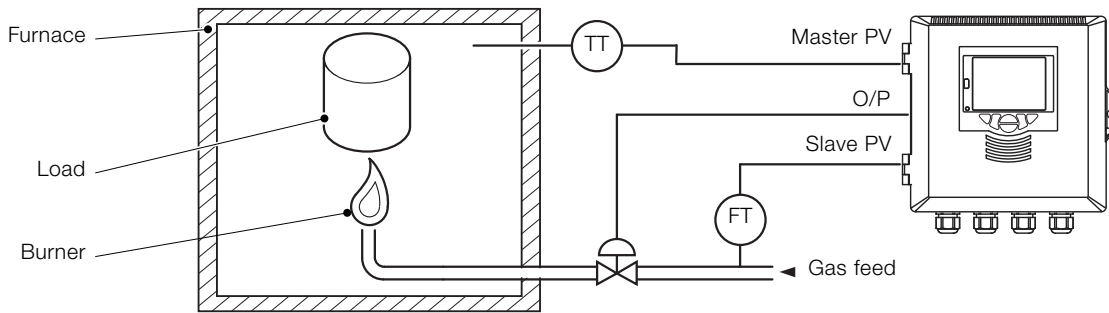

Cascade with feed-forward

This template combines the benefits of the feed-forward and cascade templates.

In this example, the effect of steam demand change on the level within the boiler drum is predicted and accounted for via the feed-forward signal. Feed water supply is then controlled accurately using a 'slave' flow loop that accounts for any variations in water supply.

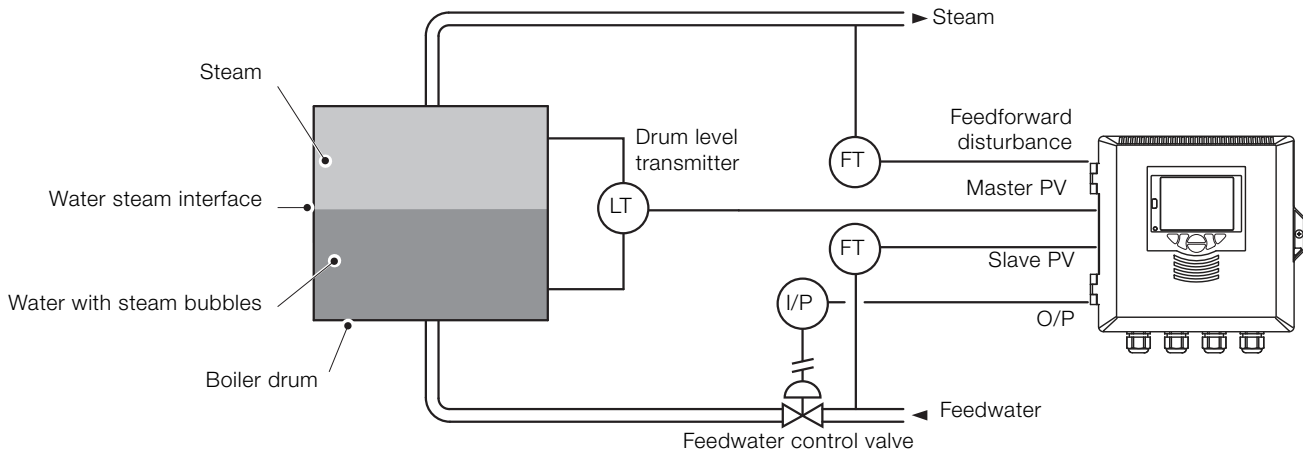

Ratio controller

The ratio controller template configures the CMF310 to regulate one process variable against another based on a specified ratio. When using the ratio control template, the CMF310's display shows the required ratio (setpoint) and the actual ratio achieved (process variable).

In this example, a controlled amount of 'Flow B' is added to 'Flow A' at a ratio programmed into the CMF310. This template is available with or without an external ratio.

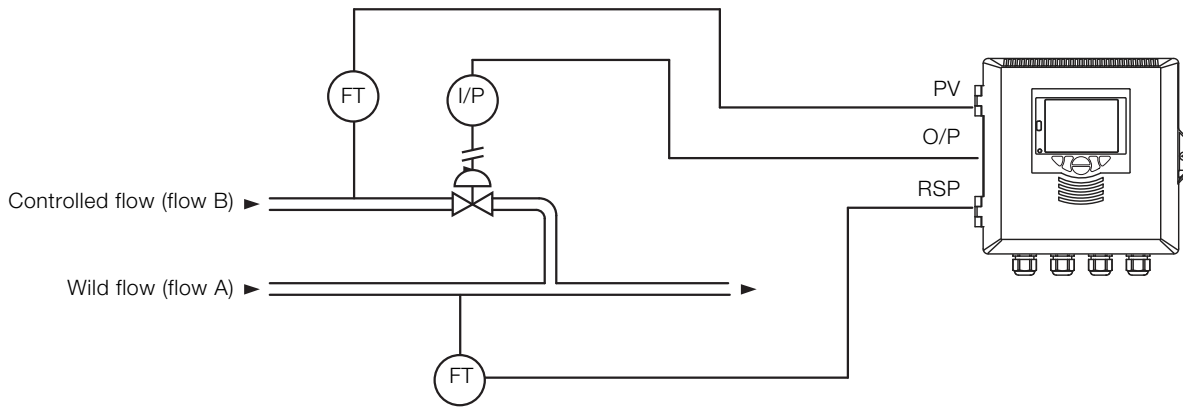

Ratio station

The ratio station template configures the CMF310 as an indicator and setpoint generator.

In this example, the CMF310 is calculating and indicating the ratio of flow A and flow B. The operator is able to enter the required ratio on the CMF310; the CMF310 then retransmits the setting to the slave controller. In many applications, the slave controller is a blind or remotely-located device. This template is available with or without an external ratio.

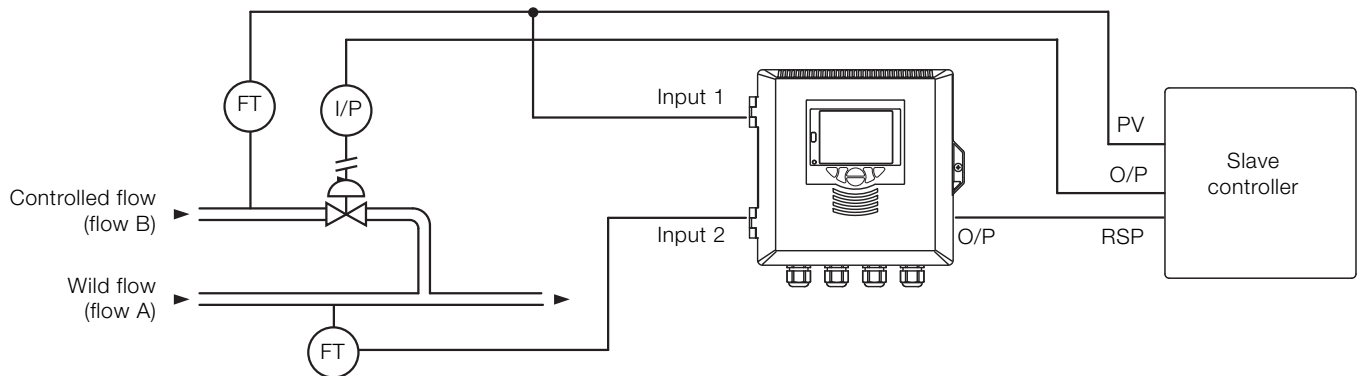

ControlMaster CMF310

Universal process controller, fieldmount

Auto / Manual station and analog backup station

These templates configure the CMF310 to backup a master controller, typically a PLC or DCS. A fault condition is detected via a low output signal from the master controller or a digital signal. On detection of a fault signal, the CMF310 can take control of the process (analog backup template), freeze its output or switch to a safe output (auto / manual station template).

In this example, a critical control of flow is backed-up by the CMF310.

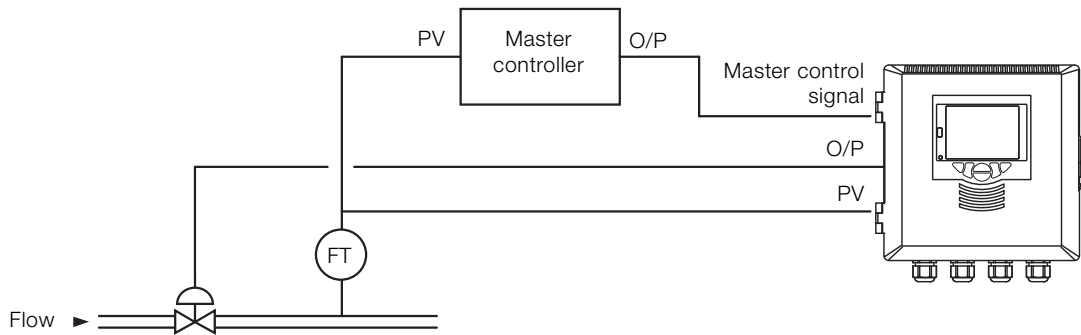

Dual loop

The dual loop template enables a CMF310 to act as 2 independent controllers and is available with a remote setpoint for either, or both, control loops. In this example, the temperature and humidity of a climatic chamber are controlled independently.

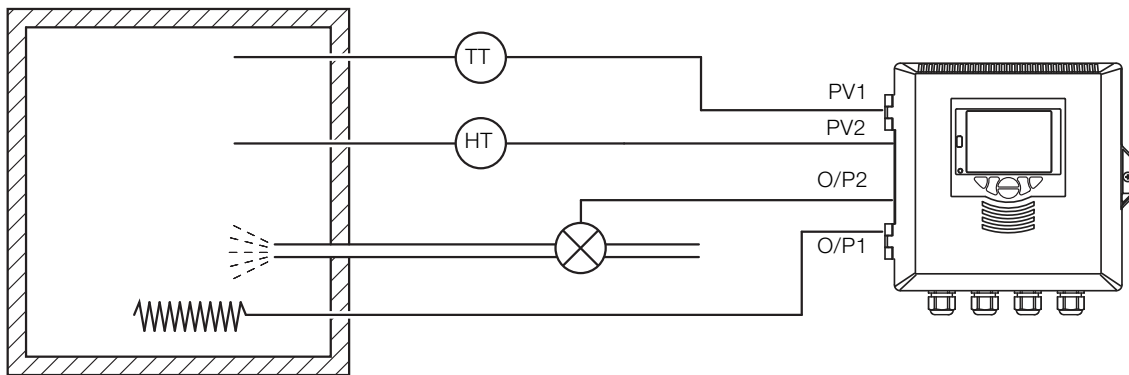

Technical specification

Operation

Display

Color, 1/4 VGA TFT, liquid crystal display (LCD) with built-in backlight

Language

English, German, French, Italian and Spanish

Operator keypad

6 tactile membrane keys

Trend display

- Recording of 2 variables
- Configurable sample rate (1 second to 5 minutes)
- 272 samples displayed on screen

Security

Password protection

Basic / Advanced – user-assigned password protection (not set at factory)

Standard functions

Control strategies

Base templates:

- Single loop with local setpoint
- Single loop with remote setpoint

Standard templates:

- Auto / Manual station (low signal detection)
- Auto / Manual station (digital signal selection)
- Analog backup station (low signal detection)
- Analog backup station (digital signal detection)
- Single indicator / manual loader station
- Dual indicator / manual loader station

Extended templates:

- Single loop with feedforward
- Single loop with feedforward and remote setpoint
- Cascade
- Cascade with remote setpoint
- Cascade with feedforward
- Ratio controller with internal ratio
- Ratio controller with external ratio
- Ratio station with internal ratio
- Ratio station with external ratio

Dual loop templates:

- Dual loop with local setpoints
- Dual loop with remote setpoint on 1 and local setpoint on 2
- Dual loop with remote setpoint on both

Control output types

Current proportioning

Time proportioning

On / Off

Motorized valve with feedback

Motorized valve without feedback

Split output – with combinations of relay, digital output and current outputs

Control parameters

Proportional band:

- 0.0 to 999.9 %

Integral*:

- 0 to 10000 s

Derivative*:

- 0.0 to 999.9 s

Manual Reset:

- 0.0 to 100.0 %

Setpoints

Local:

- 4, selectable via digital input or front panel

Remote:

- selectable via digital input or front panel keys

Profile:

- 1 program, 10 segments (Basic functionality)
- 30 programs, 140 segments (Standard functionality)

Auto tune

On-demand calculation of control settings

Process alarms

Number:

- 8

Types:

- High / Low process
- High / Low latch

Source

- Fully configurable
(for example – PV, analog input, math block inbuilt, OP control loop deviation)

Hysteresis:

- Level and time

Alarm enable:

- Enable / Disable individual alarms via a digital signal

ControlMaster CMF310

Universal process controller, fieldmount

Acknowledgement

Via front panel keys or digital signals

Real-time alarms *

Number:

– 2

Programmable:

– Time

– Day

– Duration

Math blocks *

Number:

– 8

Operators:

– +, –, x, /

– Average, Maximum, Minimum

– High / Low / Median select

– Square root

– Multiplexer

Delay timers *

Number:

– 2

Programmable:

– Delay

– Duration

Logic equations *

Number:

– 8

Elements:

– 15 per equation

Operators:

– OR, AND, NOR, NAND, NOT, EXOR

Custom linearizer *

Number:

– 2

Elements:

– 20 breakpoints

Bank control *

Number of outputs:

– 6

Wear levelling:

– Rotate or FIFO

Totalizer **

Number:

– 2 (total) 9 digit totals

Type:

– Analog, digital, frequency or pulse

Statistical calculations:

– Average, maximum, minimum (for analog signals)

Update rate:

– 125 ms

Analog inputs

Universal process inputs

Number:

– 1 Standard

– 1 Optional

Type:

– Voltage

– Current

– Resistance (ohms)

– 3-Wire RTD

– 4-Wire RTD

– Thermocouple

– Digital volt-free

– Digital 24 V

– Frequency (Input 1)

– Pulse

Non-universal process inputs

Number:

– 1 Standard

– 1 Optional

Type:

– Voltage

– Current

– Thermocouple ***

– Digital volt-free

– Digital 24 V

Thermocouple types

B, E, J, K, L, N, R, S, T

Resistance thermometer

Pt100

Other linearizations

\sqrt{x} , $x^{3/2}$, $x^{5/2}$, custom linearization

* Functionality level 'Standard' and above only

** Functionality level 'Extended'

*** Only if universal input 1 on the same input module is configured as 'Thermocouple'

Digital filter

Programmable 0 to 60 s

Display range

-9999 to 99999

Update rate

125 ms

Common mode noise rejection

> 120 dB at 50 / 60 Hz with 300 Ω imbalance resistance

Normal (series) mode noise rejection

> 60 dB at 50 / 60 Hz

CJC rejection ratio

0.05 °C/°C change in ambient temperature

Temperature stability

0.02 %/°C or 2 μV/°C (1 μV/°F)

Long term (input) drift

< 0.1 % of reading or 10 μV annually

Input impedance

> 10 MΩ (mV input)
10 Ω (mA input)

Inputs

Thermocouple	Maximum range °C (°F)	Accuracy (% of reading)
B	-18 to 1800 (0 to 3270)	0.1 % or ±2 °C (3.6 °F) * (above 200 °C [392 °F]) *
E	-100 to 900(-140 to 1650)	0.1 % or ±0.5 °C (0.9 °F)
J	-100 to 900(-140 to 1650)	0.1 % or ±0.5 °C (0.9 °F)
K	-100 to 1300 (-140 to 2350)	0.1 % or ±0.5 °C (0.9 °F)
L	-100 to 900 (-140 to 1650)	0.1 % or ±1.5 °C (2.7 °F)
N	-200 to 1300 (-325 to 2350)	0.1 % or ±0.5 °C (0.9 °F)
R	-18 to 1700 (0 to 3000)	0.1 % or ±1 °C (1.8 °F) (above 300 °C [540 °F]) *
S	-18 to 1700 (0 to 3000)	0.1 % or ±1 °C (1.8 °F) (above 200 °C [392 °F]) *
T	-250 to 300 (-400 to 550)	0.1 % or ±0.5 °C (0.9 °F) (above -150 °C [-238 °F]) *

* Accuracy is not guaranteed at temperatures below this value

RTD	Maximum range °C (°F)	Accuracy (% of reading)
Pt100	-200 to 600 (-325 to 1100)	0.1 % or ±0.5 °C (0.9 °F)

Linear inputs	Standard analog input	Accuracy (% of reading)
Millivolts	0 to 150 mV	0.1 % or ±20 μV
Milliamps	0 to 45 mA	0.2 % or ±10 μA
Volts	0 to 25 V	0.2 % or ±20 mV
Resistance (low)	0 to 550 Ω	0.2 % or ±1 Ω
Resistance (high)	0 to 10 kΩ	0.1 % or ±5 Ω
Sample Interval	125 ms per sample	

Digital inputs

Type	Volt-free or 24 V
Minimum pulse duration	Analog inputs 1 and 2: — Single inputs configured – 250 mS — Both inputs configured as analog or digital – 500 mS Analog inputs 3 and 4: — Single inputs configured – 250 mS — Both inputs configured as analog or digital – 500 mS Consider analog inputs 1/2 and 3/4 independently
Volt-free	Contact open > 10 MΩ / contact closed < 100 kΩ

Frequency input*

Frequency range	0 to 6000 Hz
1-signal	15 to 30 V
0-signal	-3 to 5 V

*For use with devices with open collector outputs

ControlMaster CMF310

Universal process controller, fieldmount

Outputs

Controls / Retransmission outputs

Number:

- 4 (2 standard, 2 optional)

Type:

- Configurable as analog or digital pulse

Isolation:

- Galvanically isolated from the rest of the circuitry, 500 V for 1 minute

Analog range:

- 0 to 20 mA programmable

Load:

- 750 Ω max.

Accuracy:

- 0.25 % of output or $\pm 10 \mu\text{A}$

Relays

Number:

- 6 (4 standard, 2 optional)

Type:

- Standard with changeover contacts

Contact ratings:

- 2 A, 240 V

Update rate:

- 125 ms

Digital I/O

Number:

- 6

Type:

- User-programmable as input or output
- Minimum input pulse duration – 125 ms

Input:

- Volt-free:
 - contact open > 10 $\text{M}\Omega$
 - contact closed < 100 $\text{K}\Omega$
- 24 V DC
 - 1-signal 15 to 30 V
 - 0-signal –3 to 5 V

– TTL

Low: 0 to 0.8 V / High: 2 to 5 V

- Conforms to IEC 61131-2

Output:

- Open collector output
- 30 V, 100 mA max. switched
- Conforms to IEC 61131-2

Update rate:

- 125 ms

2-Wire transmitter power supply

Number:

- 1 optional

Voltage:

- 24 V DC

Drive:

- 2 Loops for each transmitter PSU, 45 mA max.

Communications

Note. Only one communications option can be fitted per controller.

IrDA service port (standard)

Baud rate:

- Up to 115 kBaud

Distance:

- Up to 1 m (3 ft)

Functions:

- Firmware upgrade
- Configuration upload / download

Ethernet (optional)

Type:

- 10BaseT

Connector:

- RJ 45

Protocols:

- TCP/IP
- HTTP
- MODBUS TCP (Slave)

Web server:

- Built-in, enables remote monitoring using standard web browsers

Email

- Can be configured to be sent on the occurrence of a specified event
- Up to 3 recipients
- Up to 4 trigger sources with configurable tag

MODBUS RTU (optional)

Baud rate:

- Up to 115 kBaud

Isolation:

- Galvanically isolated from the rest of the circuitry, 500 V DC for 1 minute

EMC

Emissions & immunity

Meets requirements of IEC 61326 for an Industrial Environment

Environmental

Operating temperature range

-0 to 55 °C (32 to 131 °F)

Operating humidity range

5 to 95 % RH (non-condensing)

Storage temperature range

-20 to 70 °C (-4 to 158 °F)

Enclosure sealing

IP 66 & NEMA 4X

Safety

General safety

Pollution Degree 2, Insulation Class 1

Approvals and certifications

EN 61010-1

cULus (optional):

– UL file number E236966

UL Class 1, Division 2 (optional):

– Groups A, B, C and D

– Temperature rating T4

– In accordance with ANSI / ISA 12.12.01-2013 and
CAN / CSA C22.2 No. 213-M1987

– UL file number E474414

Isolation

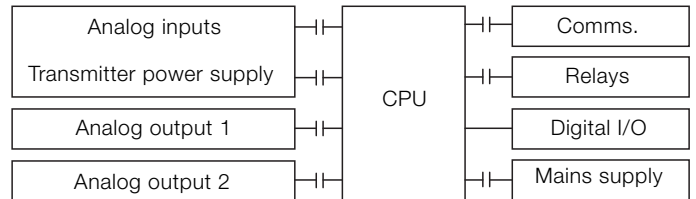

Key

—||— = Isolation

Electrical

Supply ranges

100 V to 240 V AC $\pm 10\%$ (90 V min. to 264 V max.) 50 / 60 Hz

Power consumption

25 W max.

Power interruption protection

No effect for interrupts of up to 60 ms

Physical

Size

194 x 214 x 98 mm (7.6 x 8.4 x 3.8 in.)

Weight

1.5 kg (3.3 lb) approx. (unpacked)

Panel cutout

186 x 186 mm (7.3 x 7.3 in.)

Case material

Glass-filled polycarbonate

ControlMaster CMF310

Universal process controller, fieldmount

Electrical connections

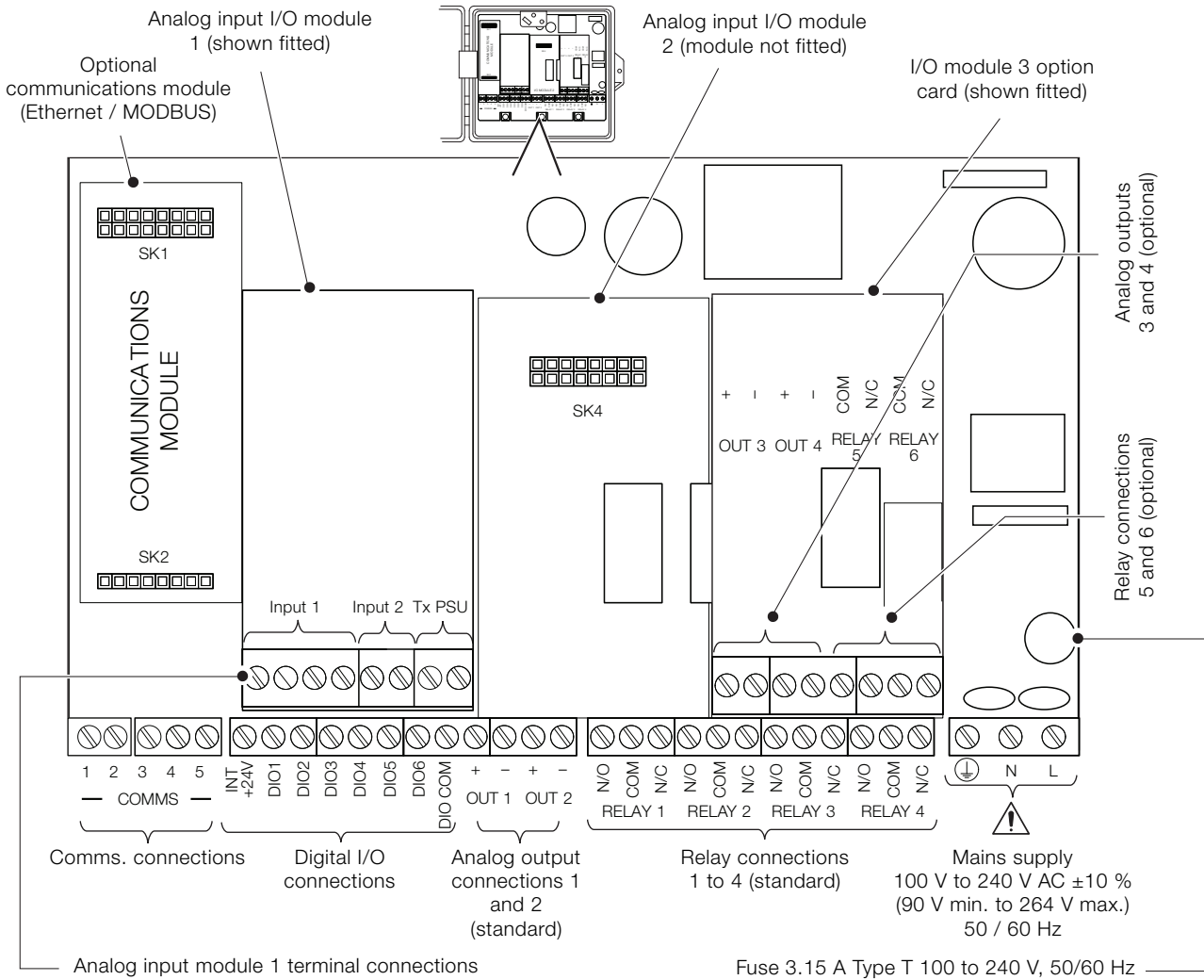

Overall dimensions

Dimensions in mm (in.)

Transmitter

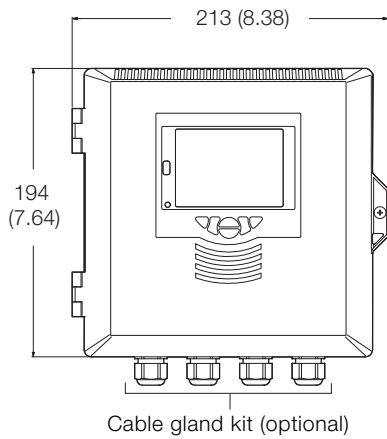

Wall mount option

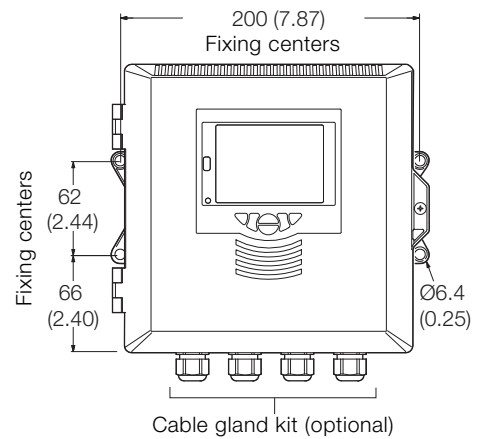

Pipe mount option

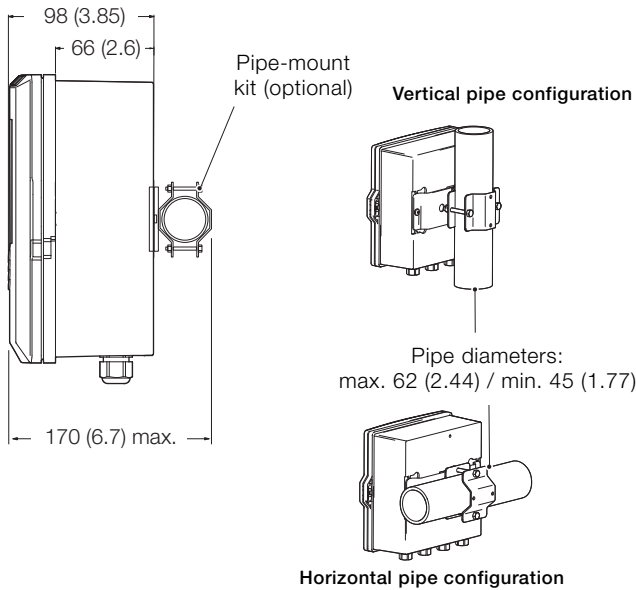

Panel mounting

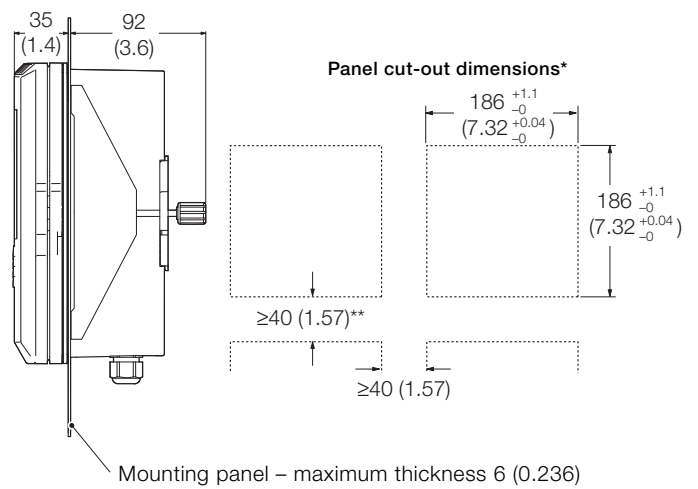

* To DIN43700

** ≥150 mm (6 in.) if (optional) cable glands fitted

ControlMaster CMF310

Universal process controller, fieldmount

Ordering information

ControlMaster CMF310 universal process controller, fieldmount	CMF310	AN	AN	AN	A	N	A	N	A	N	A	N	A	N	A	N	A	OPT
Option module 1																		
Dual analog input	A2																	
Option module 2																		
Not fitted		Y0																
Dual analog input	A2																	
Option module 3																		
Not fitted		Y0																
Analog and relay output	H2																	
Template / Functionality level																		
Base					A													
Standard					B													
Extended					C													
Dual loop					D													
Communications																		
Not fitted						0												
Ethernet						1												
RS 485 MODBUS						2												
Approval																		
Standard CE								A										
cULus approval								B										
UL Class 1 Div. 2								C										
Power Supply																		
90 to 264 V AC									1									
Branding																		
ABB Standard										A								
Unbranded front panel and start-up screen										B								
HMI Language																		
English												5						
German												1						
Spanish												3						
French												4						
Italian												2						
Expansion 1																		
None																	Y	
Configuration																		
Standard (factory default)																		1
Custom (configuration details required)																		2
Engineered (requirement details required)																		3

ControlMaster CMF310 universal process controller, fieldmount		CMF310	AN	AN	AN	A	N	A	N	A	N	A	N	A	N	A	N	A	OPT
Mounting hardware																			
Wall																		A	
Wall and panel																		B	
Cable glands																			
None (blanking plugs)																			0
Standard cable gland pack																			1
Ethernet cable gland pack																			2
Expansion 2																			
None																			Y
Calibration certificate																			
Certificate of calibration																			C1
Printed instruction manual																			
English																			M5
German																			M1
Spanish																			M3
French																			M4
Italian																			M2

Product ordering code example:

CMF310 A2 Y0 Y0 B 0 A 1 A 5 Y 1 A 1 Y-C1-M5

Standard accessories

- Included with each controller:
- Commissioning instructions

Optional accessories

- PC configuration backup kit CMF310/0714
- After-sales engineered configuration service ENG/CON
- Pipe mounting kit CM40/0700 (see page 21)
- Weathershield kit CM40/0702 (see Fig. 18)

Weathershield kit (pipe- and wall-mount installations)

Dimensions in mm (in.)

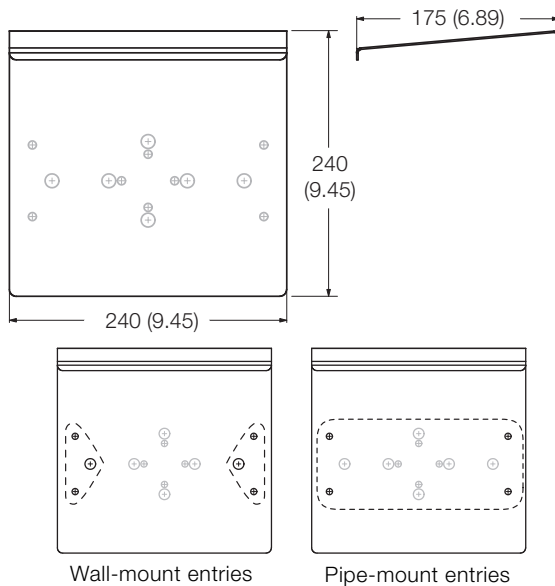

Fig. 18: Weathershield kit (pipe- and wall-mount installations)

Acknowledgements

MODBUS is a registered trademark of the Modbus-IDA organization.

Contact us

ABB Limited

Process Automation

Howard Road, St. Neots
Cambridgeshire, PE19 8EU
UK

Tel: +44 (0)870 600 6122

Fax: +44 (0)1480 213 339

Mail: enquiries.mp.uk@gb.abb.com

ABB Inc.

Process Automation

125 E. County Line Road
Warminster, PA 18974
USA

Tel: +1 215 674 6000

Fax: +1 215 674 7183

www.abb.com/measurement

Note

We reserve the right to make technical changes or modify the contents of this document without prior notice. With regard to purchase orders, the agreed particulars shall prevail. ABB does not accept any responsibility whatsoever for potential errors or possible lack of information in this document.

We reserve all rights in this document and in the subject matter and illustrations contained therein. Any reproduction, disclosure to third parties or utilization of its contents in whole or in parts – is forbidden without prior written consent of ABB.

Copyright© 2015 ABB

All rights reserved



Sales



Software



Service